



SabreCom-300 Rugged Computer System

User Manual Rev. 1.3

For model no.: SC300-VNS776-20-LNX-EG8-L2-J5-01



**FOR TECHNICAL SUPPORT
PLEASE CONTACT:**

support@diamondsystems.com

Copyright 2024
Diamond Systems Corporation
158 Commercial Street
Sunnyvale, CA 94086 USA
Tel 1-650-810-2500

www.diamondsystems.com

CONTENTS

1. IMPORTANT SAFE HANDLING INFORMATION	3
2. DESCRIPTION	4
2.1 SYSTEM FEATURES	4
2.2 OPERATING SYSTEM SUPPORT	4
2.3 MECHANICAL, ELECTRICAL, ENVIRONMENTAL	4
3. KEY SUBSYSTEMS	5
3.1 SBC	5
3.2 POWER SUPPLY	5
3.3 ETHERNET SWITCH	5
3.4 ADDITIONAL I/O	5
4. CONFIGURATION GUIDE	6
5. I/O INTERFACES	8
5.1 ETHERNET	8
5.2 USB	8
5.3 VIDEO	8
5.4 SERIAL PORTS	8
5.5 CAN PORTS	8
5.6 BACKUP BATTERY	8
5.7 I2C	9
5.8 RESET	9
5.9 PCI-104 AND ONE BANK PCIe/104 EXPANSION	9
6. SYSTEM ARCHITECTURE	10
7. SABRECOM - MECHANICAL DRAWING	11
8. SABRECOM 300 CONNECTOR LOCATIONS	12
9. I/O CONNECTOR PINOUT TABLES	13
10. I/O CONNECTOR DETAIL	17
10.1 J1: POWER INPUT	17
10.2 J3: USER CONTROL IO	18
10.3 J4: HDMI INTERFACE	20
10.4 J5: ETHERNET, CAN, SERIAL	22
10.5 J6: ETHERNET, CAN, SERIAL	25
11. EXTERNAL CABLE INTERFACE SUMMARY	28
12. VENUS JUMPER CONFIGURATIONS	29
12.1 JUMPERS ON VENUS CARRIER BOARD	29
13. BIOS KEY FEATURES	30
13.1 ENTERING THE BIOS	30
13.2 RESTORING DEFAULT BIOS SETTINGS	30
13.3 UPGRADING BIOS USING SHELL UTILITY	31
13.4 SETTING THE DATE AND TIME	32
13.5 BOOT PRIORITY	32
13.6 LED	32
13.7 QUIET / QUICK BOOT / SPLASH SCREEN	32
13.8 SERIAL PORT CONFIGURATION	32
14. GETTING STARTED	33
14.1 QUICK SETUP	33
14.2 BOOT DEVICE OPTIONS	33
14.3 INSTALLING OS AND BOOTING	33
15. VIDEO FEATURES	34
16. SERIAL PORTS AND SYSTEM CONSOLE	34
16.1 CONFIGURATION	34
16.2 CONSOLE REDIRECTION	34

1. IMPORTANT SAFE HANDLING INFORMATION



WARNING!

ESD-Sensitive Electronic Equipment

Observe ESD-safe handling procedures when working with this product.

Always use this product in a properly grounded work area and wear appropriate ESD-preventive clothing and/or accessories.

Always store this product in ESD-protective packaging when not in use.

Safe Handling Precautions

The list here describes common causes of failure found on boards returned to Diamond Systems for repair. This information is provided as a source of advice to help you prevent damaging your Diamond (or any vendor's) embedded computer boards.

ESD damage – This type of damage is usually almost impossible to detect, because there is no visual sign of failure or damage. The symptom is that the board eventually simply stops working, because some component becomes defective. Usually the failure can be identified and the chip can be replaced.

To prevent ESD damage, always follow proper ESD-prevention practices when handling computer boards.

Damage during handling or storage – On some boards we have noticed physical damage from mishandling. A common observation is that a screwdriver slipped while installing the board, causing a gouge in the PCB surface and cutting signal traces or damaging components.

Another common observation is damaged board corners, indicating the board was dropped. This may cause damage to the components or the board traces in the affected area. Most of our boards are designed with at least 25 mils clearance between the board edge and any component pad, and ground / power planes are at least 20 mils from the edge to avoid possible shorting from this type of damage. However these design rules are not sufficient to prevent damage in all situations.

A third cause of failure is when a metal screwdriver tip slips, or a screw drops onto the board while it is powered on, causing a short between a power pin and a signal pin on a component. This can cause overvoltage to components or power supply overcurrent. To avoid these faults, only perform assembly operations when the system is powered off.

Sometimes boards are stored in racks with slots that grip the edge of the board. This is a common practice for board manufacturers. However our boards are generally very dense, and if the board has components very close to the board edge, they can be damaged or even knocked off the board when the board is inserted in the rack. Diamond recommends that all our boards be stored only in individual ESD-safe packaging. If multiple boards are stored together, they should be contained in bins with dividers between boards. Do not pile boards on top of each other or cram too many boards into a small location. This can cause damage to connector pins or fragile components.

Power supply wired backwards – Our power supplies and boards are not designed to withstand a reverse power supply connection. This will destroy each IC that is connected to the power supply (i.e. almost all ICs). In this case the board will most likely will be unrepairable and must be replaced. A chip destroyed by reverse power or by excessive power will often have a visible hole on the top or show some deformation on the top surface due to vaporization inside the package. Check twice before applying power!

Board not installed properly in PC/104 stack – A common error is to install a PC/104 board accidentally shifted by 1 row or 1 column. If the board is installed incorrectly, it is possible for power and ground signals on the bus to make contact with the wrong pins on the board, which can damage the board. For example, this can damage components attached to the data bus, because it puts the $\pm 12V$ power supply lines directly on data bus lines.

Overvoltage on digital I/O line – If a digital I/O signal is connected to a voltage above the maximum specified voltage, the digital circuitry can be damaged. Always verify the valid input range of the GPIO pins on the board and the voltage levels of the intended signals before making connection to the board.

Bent connector pins – This problem is often only a cosmetic issue and is easily fixed by bending the pins back to their proper shape one at a time with needle-nose pliers. The most common cause of bent connector pins is when a PC/104 board is pulled off the stack by rocking it back and forth left to right, from one end of the connector to the other. As the board is rocked back and forth it pulls out suddenly, and the pins at the end get bent significantly. The same situation can occur when pulling a ribbon cable off of a pin header. If the pins are bent too severely, bending them back can cause them to weaken unacceptably or even break, and the connector must be replaced.

2. DESCRIPTION

SabreCom-300 is a system enclosed in a rugged enclosure. It consists of an SBC with Intel Skylake i7 Series processor at its core. The system can be powered with 9-18V DC input power supplies. The system is equipped with a module to filter out EMI and suppress surges that come in on the power supply cable to a device receiving the power that could cause interference from that device or damage or destroy the device itself. The filter design meets MIL-STD-461 requirements.

The system provides video and audio on HDMI. The system provides two ethernet ports; one of these ethernet ports is derived from I219 & the second port is implemented using I210 ethernet controllers. Also it has EPS8130 integrated inside the system which is a managed, 8-Port Gigabit Ethernet Switch. Epsilon-8130 offers 10/100/1000Mbps copper twisted pair ports on a PC/104 format board. A built-in microcontroller runs Layer 2+ managed software to control all switch functions. Both web interface and an RS-232 interface are provided to enable user access to the microcontroller for configuration and monitoring.

To communicate with the system, four serial ports are available on the system which can be configured to work in RS-232/422/485. The system also provides utilities like I2C & RESET(Internal to the system). It features DDR4 memory on board, top side conduction cooling and operation within -40 to +85C.

2.1 System features

Component	Feature	Qty
CPU	I7-7660U "Skylake", 2.8 GHz quad core	
RAM	20GB (4GB soldered + 16GB DDR4 SODIMM)	
Ethernet	1000/100/10 Mbps	8
USB 2.0	2x USB2.0	2
USB 3.0	2x USB3.0 (Optional)	2
Serial Ports	RS-232/422/485	4
RTC Battery	Power input for RTC / internal CR2032 battery included	1
Expansion	2 PCIe Minicard with PCIe x1 and USB; 1 shared with mSATA PCI-104, supports up to 4 I/O boards PCIe/104 One Bank, supports up to 4 PCIe x1 boards	
Operating system	Linux - Ubuntu 20.04 kernel 64-bit Windows 10 64-bit	

2.2 Operating System Support

SabreCom-300 ships with an installed operating system depending on the ordered configuration. The following operating systems are available:

Windows 10 64-bit

Linux – Ubuntu 64-bit

2.3 Mechanical, Electrical, Environmental

Form factor	3.66" (W) x 9.33" (D) x 6.87" (H) / 93 x 237 x 174.5mm
Cooling	Fanless conduction cooling of all internal electronics
Power input	+9V to +18V DC (without JMM-7515 power supply) 9-60VDC (with JMM-7515 power supply)
Operating Temp	-40°C to +80°C
Shock & Vibration	Designed to meet MIL-STD-810H
Weight	3.34Kg / 7.34lbs
RoHS	Compliant

3. KEY SUBSYSTEMS

3.1 SBC

The SBC in SabreCom-300 is Diamond's Venus board, based on the 7th generation Intel Kaby lake processor i7-7660U. The U-series processors are offered in a 1-chip platform that includes the 7th generation Intel Platform Controller Hub (PCH) die on the same package as the processor die. It is a dual core, 64 bit processor with a processor base frequency of 2.5GHz and maximum turbo frequency of 4GHz. The system memory consists of 4GB Soldered down memory on memory channel 1 and 16GB SODIMM on memory channel 2, for a total of 20GB available DRAM.

3.2 Power Supply

Three input voltage ranges are available based on the ordering configuration.

J option: This configuration includes a rugged MIL-qualified **isolated** power supply featuring MIL-STD-461, -704, and -1275 compliance. These models support an input voltage range of 9-60VDC. These systems support an internal power consumption of up to 80W (typical power consumption of a SabreCom-Venus system with no additional I/O expansion modules is 25W).

N option: This configuration includes a rugged MIL-qualified **non-isolated** power supply featuring MIL-STD-461, -704, and -1275 compliance. These models support an input voltage range of 5-36VDC. These systems support an internal power consumption of up to 90W (18V power supply output setting).

F option: This configuration includes a MIL-STD-461 filter board. This configuration supports an input voltage range of 9-18VDC.

3.3 Ethernet Switch

Depending on the model configuration, SabreCom-300 includes an 8-port or 16-port Gigabit Ethernet switch. The 8-port configuration uses Diamond's EPS-8130 switch, and the 16-port configuration uses Diamond's EPS-24016-104 switch. The switch is mounted on top of the SBC.

There is no bus connection between the SBC and the switch, the only connection is via Ethernet. One port of the switch is connected to the host SBC, reducing the number of externally accessible switch ports by one. The SBC itself provides two Gigabit Ethernet ports: one is connected to the switch, and one is brought to the I/O connectors.

3.4 Additional I/O

Depending on the model configuration, SabreCom-300 may contain additional I/O beyond that provided by the SBC and switch. This additional I/O is integrated onto the front panel I/O connectors. Detailed behavior of any additional I/O is generally contained in separate documentation, however this manual will contain complete details of the connector pinouts.

This model of SabreCom-300 includes 2 CAN ports. These ports are provided by an installed JNMM-2LP-XT PC/104-Plus I/O card. Please refer to the user manual for this board for further information about these CAN ports and how to use them.

4. CONFIGURATION GUIDE

SabreCom-300 can be configured for a large variety of features. A spreadsheet on the Diamond Systems website is used to select each available option and create an ordering part number and description:

		Part number builder text	Part description builder text
Base model (no selection required)		SC300-	SabreCom-300,
SBC	*Venus 776KL-20	VNS776-20	i7-7600U CPU, 20GB RAM,
Operating system	*Linux 64-bit	-LNX	Linux,
Ethernet switch	*8 Gbe copper ports	-EG8	8-Port Gbe Switch,
Switch firmware	*Webstax Layer 2+	-L2	Layer 2+ FW,
Power supply	*MIL with isolation	-J	MIL Iso Power,
Integrated mass storage	*1TB	1	1TB SSD
Expansion I/O	*My system has no additional I/O requirements	-01	
	<Enter additional I/O details here. Cell will expand as needed.>		
Your system part number:	SC300-VNS776-20-LNX-EG8-L2-J1-01		
Your system description:	SabreCom-300, i7-7600U CPU, 20GB RAM, Linux, 8-Port Gbe Switch, Layer 2+ FW, MIL Iso Power, 1TB SSD		

The available choices for each option may change from time to time. As of the release date of this manual, the following choices are available:

SBC

- *Venus 776KL-20
- Jasper 1185GRE-32
- Jasper 1185G7E-64
- Jasper 1365URE-64

Operating system

- *Linux 64-bit
- Windows 10 64-bit

Ethernet switch

- *8 Gbe copper ports
- 16 Gbe copper ports
- No Ethernet switch

Switch firmware

- *Webstax Layer 2+
- IStaX Layer 3
- No Ethernet switch

Power supply

*MIL with isolation

MIL without isolation

MIL-STD-461 filter

Integrated mass storage

*1TB

2TB

512GB

128GB

Expansion I/O

*My system has no additional I/O requirements

My system requires additional I/O

An example part number and description selecting all default choices is as follows:

System part number: **SC300-VNS776-20-LNX-EG8-L2-J1-01**

SabreCom-300, i7-7600U CPU, 20GB RAM, Linux, 8-Port Gbe Switch, Layer 2+ FW,

System description: **MIL Iso Power, 1TB SSD**

5. I/O INTERFACES

5.1 Ethernet

The system provides 8 or 16 Gigabit Ethernet ports. All but one port is derived from the integrated Ethernet switch. One port is connected directly to the SBC.

5.2 USB

The system provides two dedicated USB 2.0 ports and two USB 3.0 ports (Optional) which are backward compatible to USB2.0.

Two of the USB3.0 ports are terminated on the 22 pin SJT00RT12-35DS014 connector on the front panel, while the USB2.0 ports are terminated on the 37-pin D38999/20WD35SN connector on the front panel.

5.3 Video

The system offers one HDMI display output terminated on the 22 pin SJT00RT12-35DS014 connector on the front panel.

5.4 Serial Ports

The system provides 4 serial ports using the Exar XR28V384 LPC UART. RS-232/422/485 protocols are supported with Exar SP336 multiprotocol transceivers. In RS-232 mode, only signals TX, RX, RTS, and CTS are provided. The protocol selection and TX / RX 121 ohm line termination resistors for RS-422/485 are controlled using GPIO pins from the processor and are configurable via BIOS configuration screens as well as via application software.

Console redirection feature (using a serial port for keyboard input and terminal display via a link to a second computer) is provided in the BIOS on COM1.

The serial ports 1 & 2 are terminated on the 55-pin D38999/26WE35PN connector & the serial ports 3 & 4 are terminated on the 55-pin D38999/26WE35PA connector on the front panel.

5.5 CAN Ports

This model of SabreCom-300 provides 2 CAN interface through JANUS-MM-LP PC-104 adaptor. The CAN transceivers are Analog Devices ADM3053 with a combination of isolation and transceiver. The device is powered by +5V. It generates isolated power to power the isolated side of the transceiver and the transceivers feature programmable slope control with a resistor. Janus-MM-2LP supports 500V isolation between each CAN port and the host, and between each CAN port and the other via the ADM3053 isolated transceiver. The CAN interfaces are terminated on the 55-pin D38999/26WE35PA connector on the front panel.

5.6 Backup Battery

The system contains an on-board RTC battery holder for placing BR-2032/BN coin battery.

The system boots and functions properly without a backup battery installed.

5.7 I2C

The system provides access to a 3.3V level I2C interface directly from the processor.

5.8 Reset

The system provides access to RESET signal to hard reset the system.

5.9 PCI-104 and One Bank PCIe/104 Expansion

SabreCom-300 offers I/O expansion via a PCI-104 connector, a PCIe/104 OneBank connector, and a PCIe/USB minicard socket. A maximum of one minicard plus one PCI-104 OR PCIe/104 I/O module can be installed in the standard width enclosure. The PCIe/104 connector can support up to a maximum of 3 I/O cards if the enclosure width is increased. The increased PC104 stack height may reduce the system's upper limit of shock and vibration tolerance.

6. SYSTEM ARCHITECTURE

Figure 1 provides an overview of the block diagram of the SabreCom-300 system.

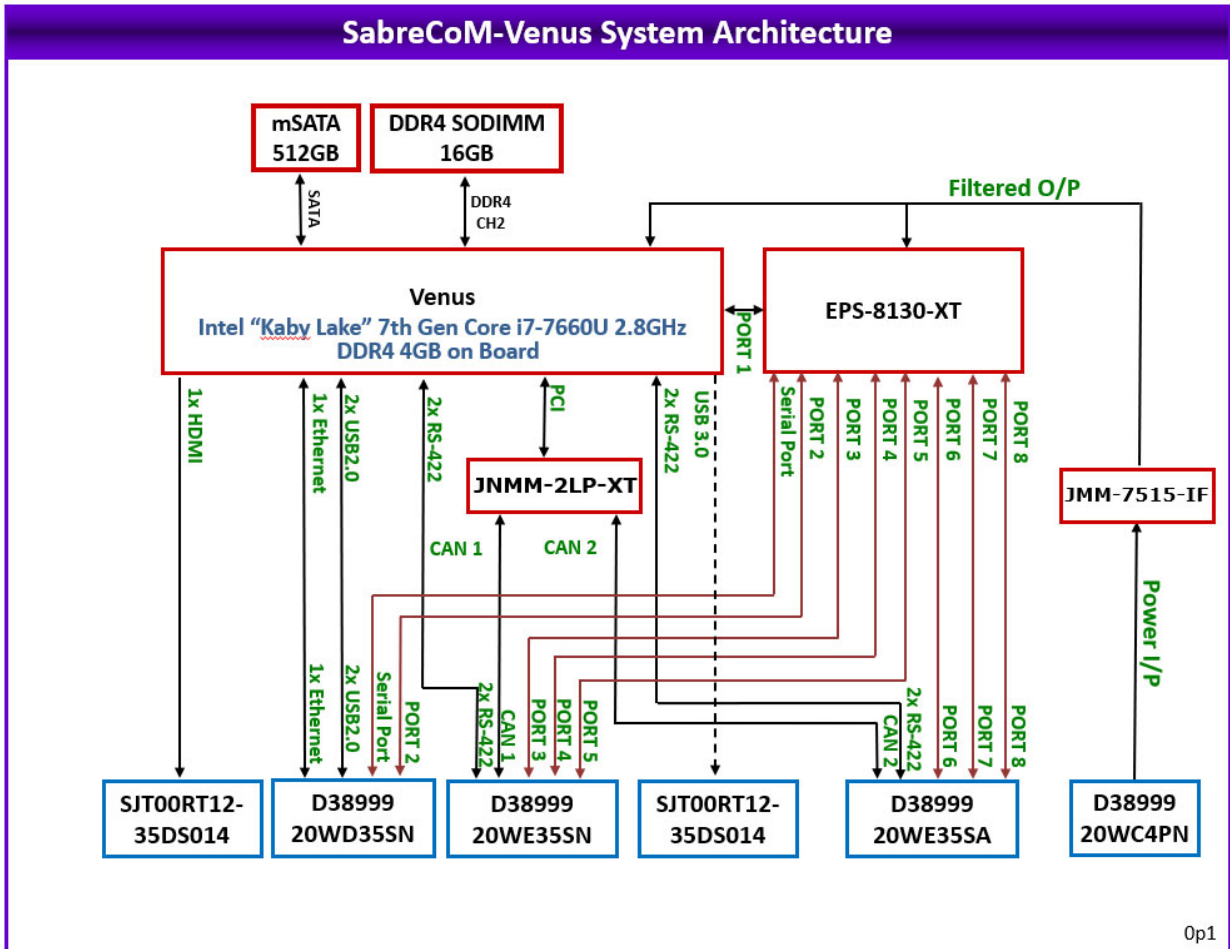

Figure 1: System Architecture of SabreCom-300

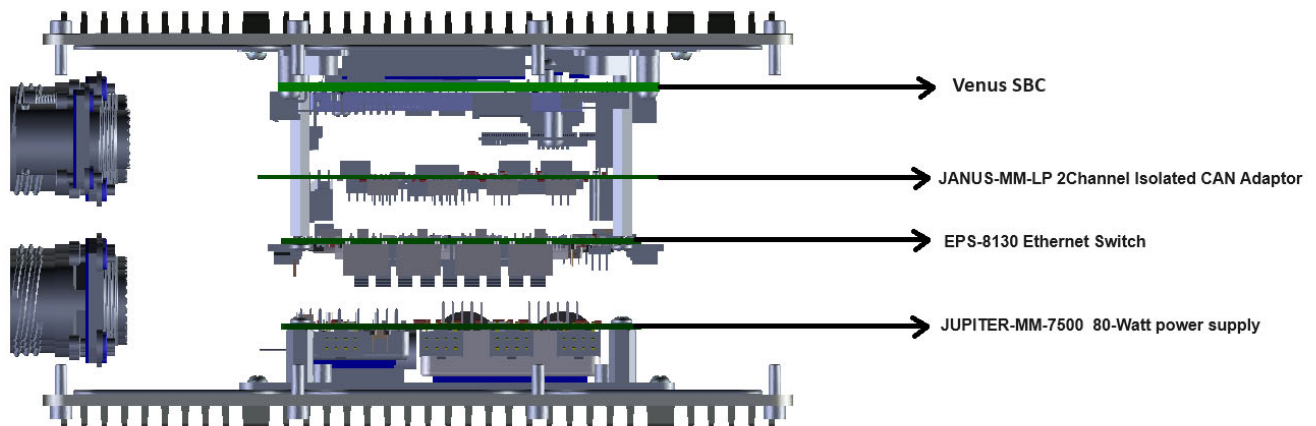
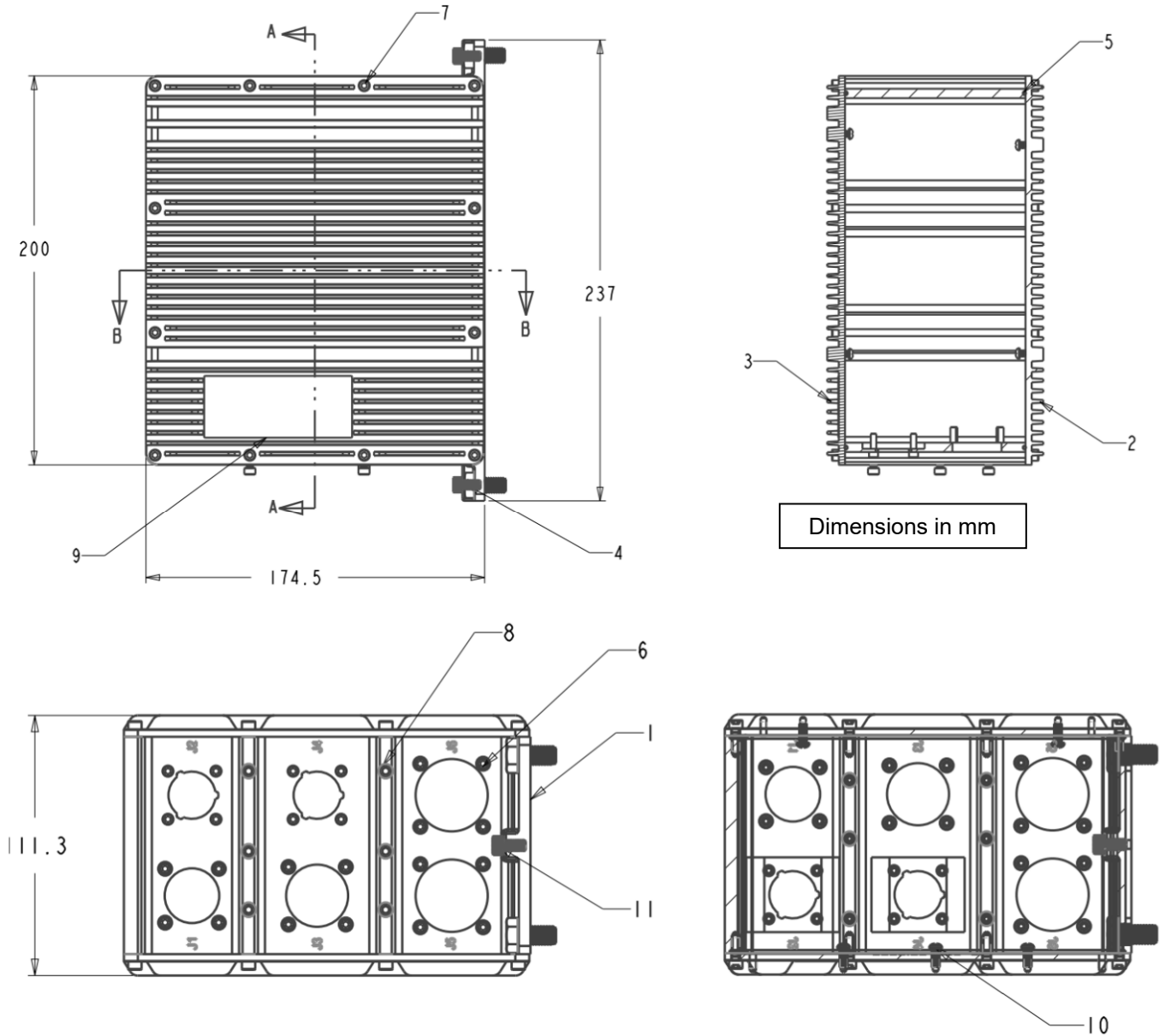

Figure 2: Inner View of SabreCom-300 with Optional PCI-104 CAN I/O Expansion Module

7. SABRECOM - MECHANICAL DRAWING



11	#10-32 SOCKET CAP SCREW #92196A267	ST. STEEL	9.5 MM (3/8")	02
10	M3X8 PAN PH. HEAD SCREW #92000A118	ST. STEEL	8 MM	10
9	LABEL-TOP SC-300 VNS	PC FILM	76.2 X 31.7 X 0.254	01
8	#6-32 SOCKET CAP SCREW #93705A145	ST. STEEL	8 MM(0.313")	06
7	#6-32 SOCKET CAP SCREW #92196A147	ST. STEEL	12 MM(0.475")	24
6	#4-40 SOCKE CAP SCREW W/SEAL#95198A275	ST. STEEL	9.5 MM(0.375")	24
5	SC VNS IDF GASKET WS-1103-SI660	ELASTOMER	Ø1.6 X 705	02
4	M8X16 HEX HEAD SCREW #91310A530	ST. STEEL	16 MM	04
3	SC-300 VNS 01 RIGHT LID #7820127_1	AL 6063 T-5	200 X 174 X 9.14	01
2	SC-300 VNS 01 LEFT LID #7820126_1	AL 6063 T-5	200 X 174 X 9.14	01
1	SC-300 VNS 01 CASE BODY #7820125_1	AL 6063 T-5	237 X 174.5 X 93	01
SL.NO.	DESCRIPTION	MATERIAL	SIZE IN MM	QTY

8. SABRECOM 300 CONNECTOR LOCATIONS

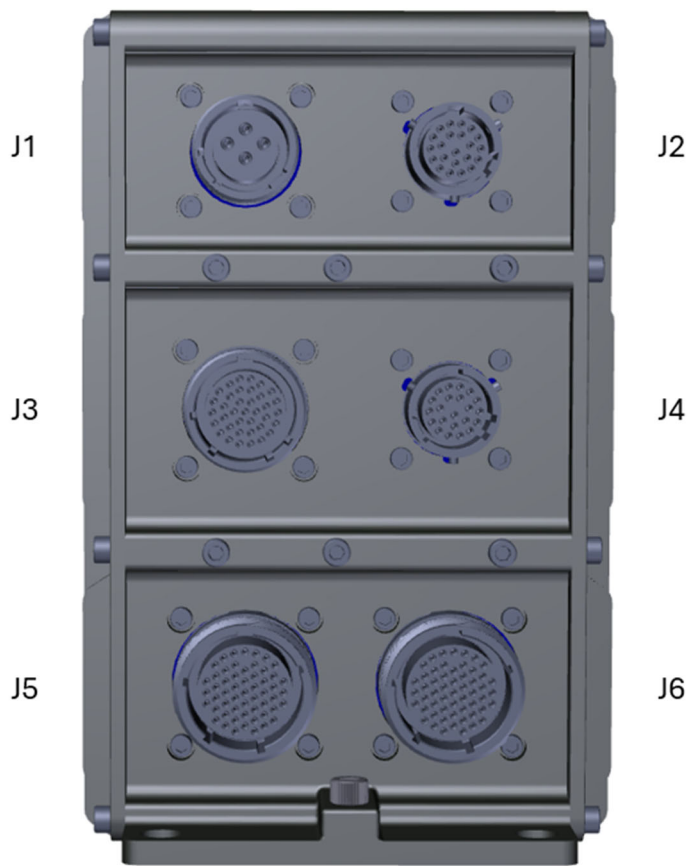

Silk Screen Marking	MIL D38999 Connector	Available Interfaces
J1	D38999/20KC4PN	Power
J2	SJT00RT12-35DS014 (optional, otherwise a dummy connector is installed)	2xUSB3.0 (Optional)
J3	D38999/20WD35SN	3x Gigabit Ethernet, SBC Port-1, SBC Port-2, EPS Port-2
		1x Debug Serial Port
		2x USB2.0 Port 5-6
J4	SJT00RT12-35DS014	1X HDMI
J5	D38999/20WE35SN	3x Gigabit Ethernet, Port 3-5
		2x RS422, Port 1-2
		1x CAN Port-1
J6	D38999/20WE35SN	3x Gigabit Ethernet, Port 6-8
		2x RS422, Port 3-4
		1x CAN Port-2

9. I/O CONNECTOR PINOUT TABLES

The tables below show the pin assignments of all outward facing I/O connectors. Pin locations without any associated signal are no-connect pins.

These pinout tables are specific to the model number of SabreCom-300 shown on the title page of this manual. Connector pinouts vary based on the product configuration.

J1, Power In (D38999/20WC4PN) 4 x #16	
Pin	Description
A	Common
B	Common
C	Positive 28V
D	Positive 28V

J2, Serial comms, Ethernet (D38999/20WE35SN) 55 x #22D	
Pin	Description
1	BI_DA+_P3
2	BI_DA-_P3
3	BI_DB+_P3
4	BI_DC+_P3
5	BI_DC-_P3
6	BI_DD+_P3
7	BI_DD-_P3
8	BI_DB-_P3
9	
10	BI_DA+_P4
11	BI_DA-_P4
12	BI_DB+_P4
13	BI_DB-_P4
14	
15	
16	
17	BI_DC+_P4
18	BI_DC-_P4
19	BI_DD+_P4
20	BI_DD-_P4
21	
22	
23	
24	

From Ethernet
Switch port 3

From Ethernet
Switch port 4

From Ethernet
Switch port 4

J3, Serial comms, Ethernet (D38999/20WE35SA) 55 x #22D	
Pin	Description
1	BI_DA+_P6
2	BI_DA-_P6
3	BI_DB+_P6
4	BI_DC+_P6
5	BI_DC-_P6
6	BI_DD+_P6
7	BI_DD-_P6
8	BI_DB-_P6
9	
10	BI_DA+_P7
11	BI_DA-_P7
12	BI_DB+_P7
13	BI_DB-_P7
14	
15	
16	
17	BI_DC+_P7
18	BI_DC-_P7
19	BI_DD+_P7
20	BI_DD-_P7
21	
22	
23	
24	

From Ethernet
Switch port 6

From Ethernet
Switch port 7

From Ethernet
Switch port 7

25	BI_DA+_P5	From Ethernet Switch port 5	25	BI_DA+_P8	From Ethernet Switch port 8
26	BI_DB+_P5		26	BI_DB+_P8	
27	BI_DC+_P5		27	BI_DC+_P8	
28	BI_DD+_P5		28	BI_DD+_P8	
29			29		
30			30		
31			31		
32	BI_DA-_P5	From Ethernet Switch port 5	32	BI_DA-_P8	From Ethernet Switch port 8
33	BI_DB-_P5		33	BI_DB-_P8	
34	BI_DC-_P5		34	BI_DC-_P8	
35	BI_DD-_P5		35	BI_DD-_P8	
36			36		
37			37		
38			38		
39			39		
40	RS422_GND1	From Venus SBC port 1	40	RS422_GND3	From Venus SBC port 3
41	RS422_RX1-		41	RS422_RX3-	
42	RS422_RX1+		42	RS422_RX3+	
43	RS422_TX1-		43	RS422_TX3-	
44	RS422_TX1+		44	RS422_TX3+	
45			45		
46			46		
47	RS422_GND2	From Venus SBC port 2	47	RS422_GND4	From Venus SBC port 4
48	RS422_RX2-		48	RS422_RX4-	
49	RS422_RX2+		49	RS422_RX4+	
50	RS422_TX2-		50	RS422_TX4-	
51	RS422_TX2+		51	RS422_TX3+	
52			52		
53	CAN 1_H		53	CAN 2_H	
54	CAN 1_L		54	CAN 2_L	
55	CAN 1_GND		55	CAN 2_GND	

J4, HDMI (SJT00RT12-35DS014)
22 x #22

Pin	Description
1	HDMI_DP2_TX0_CON_P
2	HDMI_DP2_TX0_CON_N
3	HDMI_DP2_TX1_CON_P
4	HDMI_DP2_TX1_CON_N
5	HDMI_DP2_TX2_CON_P
6	HDMI_DP2_TX2_CON_N
7	HDMI_HPD_CON
8	
9	HDMI_DP2_TX3_CON_P
10	HDMI_DP2_TX3_CON_N
11	
12	HDMI_SCL_CON
13	HDMI_SDA_CON
14	GND_DIG
15	GND_DIG
16	GND_DIG
17	GND_DIG
18	
19	GND_DIG
20	HDMI_CEC_CON
21	V_5P0_HDMI
22	GND_DIG

J5, Diagnostic port (D38999/20WD35SN) 37 x #22D	
Pin	Description
1	BI_DA+_SBC_P2
2	BI_DA-_SBC_P2
3	BI_DB+_SBC_P2
4	BI_DB-_SBC_P2
5	
6	BI_DA+_P2
7	BI_DA-_P2
8	BI_DB+_P2
9	BI_DB-_P2
10	
11	USB2.0P1Vcc
12	USB2.0P1D-
13	USB2.0P1D+
14	USB2.0P1Gnd
15	USB2.0P2Vcc
16	USB2.0P2D-
17	USB2.0P2D+
18	USB2.0P2Gnd
19	BI_DC+_SBC_P2
20	BI_DC-_SBC_P2
21	BI_DD+_SBC_P2
22	BI_DD-_SBC_P2
23	BI_DC+_P2
24	BI_DC-_P2
25	BI_DD+_P2
26	BI_DD-_P2
27	
28	
29	
30	
31	
32	
33	
34	
35	
36	
37	

From Venus SBC
port 2

From Ethernet
Switch port 2

From Venus SBC
USB2.0 port 1

From Venus SBC
USB2.0 port 2

From Venus SBC
port 2

From Ethernet
Switch port 2

10. I/O CONNECTOR DETAIL

These pinout specifications are specific to the model number of SabreCom-300 shown on the title page of this manual. Connector pinouts vary based on the product configuration.

10.1 J1: Power Input

SabreCom-Venus provides a C-size D38999 series circular connector with pin terminals for power input.

Function: Power input

Enclosure location: J1 (Top Left)

Connector Description

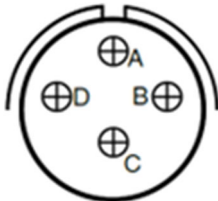
Internal connector	Connector type	MIL D38999/20WC4PN	
	Description	Shell type	Wall Mount Receptacle
		Material and finish	Olive Drab Cadmium
		Shell Size	C
		Insert Arrangement	C4
		Contact type	Pin
		Keying position	Normal Keying
Mating connector	Connector type	MIL D38999/26WC4SN	
	Description	Shell type	Straight Plug
		Material and finish	Passivated Stainless Steel
		Shell Size	C
		Insert Arrangement	C4
		Contact type	Socket
		Keying position	Normal Keying
		Pins	4
Illustration	<ul style="list-style-type: none"> • View from exterior of case • View from terminal insertion side of mating connector 		

Wiring Table:

D38999 Pin no.	Signal
A	Ground
B	Ground
C	Vin
D	Vin

10.2 J3: User Control IO

SabreCom-300 provides 2x Ethernet, 2x USB 2.0 and one serial port on D38999 series circular connector.

Function: Ethernet port 1-2, USB port 1-2, Serial debug port

Enclosure location: J3 (Middle Left)

Internal connector	Connector type	MIL D38999/20WD35SN													
	Description	<table border="0"> <tr> <td>Shell type</td> <td>Straight Plug</td> </tr> <tr> <td></td> <td>Olive Drab Cadmium Plated</td> </tr> <tr> <td>Material and finish</td> <td>Nickel Base</td> </tr> <tr> <td>Shell Size</td> <td>D</td> </tr> <tr> <td>Insert Arrangement</td> <td>D35</td> </tr> <tr> <td>Contact type</td> <td>Socket</td> </tr> <tr> <td>Keying position</td> <td>Normal Keying</td> </tr> </table>	Shell type	Straight Plug		Olive Drab Cadmium Plated	Material and finish	Nickel Base	Shell Size	D	Insert Arrangement	D35	Contact type	Socket	Keying position
Shell type	Straight Plug														
	Olive Drab Cadmium Plated														
Material and finish	Nickel Base														
Shell Size	D														
Insert Arrangement	D35														
Contact type	Socket														
Keying position	Normal Keying														
Mating connector	Connector type	MIL D38999/26WD35PN													
	Description	<table border="0"> <tr> <td>Shell type</td> <td>Straight Plug</td> </tr> <tr> <td>Material and finish</td> <td>Olive Drab Cadmium Plated</td> </tr> <tr> <td></td> <td>Nickel Base</td> </tr> <tr> <td>Shell Size</td> <td>D</td> </tr> <tr> <td>Insert Arrangement</td> <td>D35</td> </tr> </table>	Shell type	Straight Plug	Material and finish	Olive Drab Cadmium Plated		Nickel Base	Shell Size	D	Insert Arrangement	D35			
Shell type	Straight Plug														
Material and finish	Olive Drab Cadmium Plated														
	Nickel Base														
Shell Size	D														
Insert Arrangement	D35														
Illustration	<ul style="list-style-type: none"> • View from exterior of case • View from terminal insertion side of mating connector 														

Wiring Table

No. of positions in connector: 37

No. of positions used: 28

No. of positions unused: 9

D38999/ 26WD35PN Pin no.	Signal	External Connector Type	External connector Pin no.	Wire colour
6	BI_DA+ P2	RJ45 jack Ethernet Port 2	1	White-Orange
7	BI_DA- P2		2	Orange
8	BI_DB+ P2		3	White-Green
9	BI_DB- P2		6	Green
23	BI_DC+ P2		4	Blue
24	BI_DC- P2		5	White-Blue
25	BI_DD+ P2		7	White-Brown
26	BI_DD- P2		8	Brown
1	BI_DA+ SBC P2	RJ45 jack Ethernet Port 1	1	White-Orange
2	BI_DA- SBC P2		2	Orange
3	BI_DB+ SBC P2		3	White-Green
4	BI_DB- SBC P2		6	Green
19	BI_DC+ SBC P2		4	Blue
20	BI_DC- SBC P2		5	White-Blue
21	BI_DD+ SBC P2		7	White-Brown
22	BI_DD- SBC P2		8	Brown
11	USB2.0P1Vcc	USB2.0 Port 1 Type A- Female	1	Red
12	USB2.0P1D-		2	White
13	USB2.0P1D+		3	Green
14	USB2.0P1Gnd		4	Black
15	USB2.0P2Vcc	USB2.0 Port 2 Type A- Female	1	Orange
16	USB2.0P2D-		2	Yellow
17	USB2.0P2D+		3	Blue
18	USB2.0P2Gnd		4	Brown
29	TX1/TX1_P/RX1_P	DB9-1 Male	2	Black
28	RX1/RX1_P		3	Black
30	GND_DIG		5	Red

10.3 J4: HDMI Interface

SabreCom-300 provides 1x HDMI, on SJT series circular connector.

Function: HDMI

Enclosure location: J4 (Middle Right)

Connector description

Internal connector	Connector type	MIL SJT00RT12-35DS014											
	Description	<table border="0"> <tr> <td>Shell type</td> <td>Straight Plug</td> </tr> <tr> <td>Material and finish</td> <td>NA Flange receptacle with socket contacts</td> </tr> <tr> <td>Shell Size</td> <td>12-35</td> </tr> <tr> <td>Insert Arrangement</td> <td>12-35</td> </tr> <tr> <td>Contact type</td> <td>Socket</td> </tr> <tr> <td>Keying position</td> <td>Normal Keying</td> </tr> </table>	Shell type	Straight Plug	Material and finish	NA Flange receptacle with socket contacts	Shell Size	12-35	Insert Arrangement	12-35	Contact type	Socket	Keying position
Shell type	Straight Plug												
Material and finish	NA Flange receptacle with socket contacts												
Shell Size	12-35												
Insert Arrangement	12-35												
Contact type	Socket												
Keying position	Normal Keying												
Mating connector	Connector type	MIL SJTG06RT12-35DP014											
	Description	<table border="0"> <tr> <td>Shell type</td> <td>Straight Plug</td> </tr> <tr> <td>Material and finish</td> <td>Olive Drab Cadmium Plated Nickel Base</td> </tr> <tr> <td>Shell Size</td> <td>12</td> </tr> <tr> <td>Insert Arrangement</td> <td>12-35</td> </tr> <tr> <td>Contact type</td> <td>Pin</td> </tr> <tr> <td>Keying position</td> <td>Normal Keying</td> </tr> </table>	Shell type	Straight Plug	Material and finish	Olive Drab Cadmium Plated Nickel Base	Shell Size	12	Insert Arrangement	12-35	Contact type	Pin	Keying position
Shell type	Straight Plug												
Material and finish	Olive Drab Cadmium Plated Nickel Base												
Shell Size	12												
Insert Arrangement	12-35												
Contact type	Pin												
Keying position	Normal Keying												
Illustration	<ul style="list-style-type: none"> • View from exterior of case • View from terminal insertion side of mating connector 												

Wiring Table

No. of positions in connector: 22

No. of positions used: 18

No. of positions unused: 4

SJT Pin no.	Signal	Connector Type	External connector Pin no.
1	HDMI_DP2_TX0_CON_P	HDMI Female	1
2	HDMI_DP2_TX0_CON_N		3
15	GND_DIG		2
3	HDMI_DP2_TX1_CON_P		4
4	HDMI_DP2_TX1_CON_N		6
16	GND_DIG		5
5	HDMI_DP2_TX2_CON_P		7
6	HDMI_DP2_TX2_CON_N		9
17	GND_DIG		8
9	HDMI_DP2_TX3_CON_P		10
10	HDMI_DP2_TX3_CON_N		12
19	GND_DIG		11
20	HDMI_CEC_CON		13
	NC		14
12	HDMI_SCL_CON		15
13	HDMI_SDA_CON		16
14	GND_DIG		17
21	V_5P0_HDMI		18
7	HDMI_HPD_CON	19	
22	GND_DIG		NC
11	GND_CHASSIS		NC
18	GND_CHASSIS		NC
8	NC		NC

10.4 J5: Ethernet, CAN, Serial

SabreCom-300 provides 3x Ethernet, 1x CAN, 2x Serial ports and these signals terminated on a E-sized D38999 series circular connector. All the above mentioned interfaces share the same connector.

Function: Ethernet port 3-5, CAN port-1, Serial port 1-2

Enclosure location: J5 (Lower Left)

Cable description

Internal connector	Connector type	MIL D38999/20WE35SN													
	Description	<table border="0"> <tr> <td>Shell type</td> <td>Straight Socket</td> </tr> <tr> <td></td> <td>Olive Drab Cadmium</td> </tr> <tr> <td>Material and finish</td> <td>Plated Nickel Base</td> </tr> <tr> <td>Shell Size</td> <td>E</td> </tr> <tr> <td>Insert Arrangement</td> <td>E35</td> </tr> <tr> <td>Contact type</td> <td>Socket</td> </tr> <tr> <td>Keying position</td> <td>Normal Keying</td> </tr> </table>	Shell type	Straight Socket		Olive Drab Cadmium	Material and finish	Plated Nickel Base	Shell Size	E	Insert Arrangement	E35	Contact type	Socket	Keying position
Shell type	Straight Socket														
	Olive Drab Cadmium														
Material and finish	Plated Nickel Base														
Shell Size	E														
Insert Arrangement	E35														
Contact type	Socket														
Keying position	Normal Keying														
Mating connector	Connector type	MIL D38999/26WE35PN													
	Description	<table border="0"> <tr> <td>Shell type</td> <td>Straight Plug</td> </tr> <tr> <td></td> <td>Olive Drab Cadmium</td> </tr> <tr> <td>Material and finish</td> <td>Plated Nickel Base</td> </tr> <tr> <td>Shell Size</td> <td>E</td> </tr> <tr> <td>Insert Arrangement</td> <td>E35</td> </tr> <tr> <td>Contact type</td> <td>Pin</td> </tr> <tr> <td>Keying position</td> <td>Normal Keying</td> </tr> </table>	Shell type	Straight Plug		Olive Drab Cadmium	Material and finish	Plated Nickel Base	Shell Size	E	Insert Arrangement	E35	Contact type	Pin	Keying position
Shell type	Straight Plug														
	Olive Drab Cadmium														
Material and finish	Plated Nickel Base														
Shell Size	E														
Insert Arrangement	E35														
Contact type	Pin														
Keying position	Normal Keying														
Illustration	<ul style="list-style-type: none"> View from exterior of case View from terminal insertion side of mating connector 	<p>The diagram shows a circular connector with 35 pins arranged in a circular pattern. The pins are numbered 1 through 35. A legend on the right side of the diagram identifies the color coding for the pins:</p> <ul style="list-style-type: none"> Ethernet Port-3: Blue Ethernet Port-4: Orange Ethernet Port-5: Pink CAN Port 1: Green Serial 1-2: Grey <p>The pins are arranged in a circular pattern with the following color coding:</p> <ul style="list-style-type: none"> Pin 1: Blue (Ethernet Port-3) Pin 2: Blue (Ethernet Port-3) Pin 3: Blue (Ethernet Port-3) Pin 4: Blue (Ethernet Port-3) Pin 5: Blue (Ethernet Port-3) Pin 6: Blue (Ethernet Port-3) Pin 7: Blue (Ethernet Port-3) Pin 8: Blue (Ethernet Port-3) Pin 9: Blue (Ethernet Port-3) Pin 10: Orange (Ethernet Port-4) Pin 11: Orange (Ethernet Port-4) Pin 12: Orange (Ethernet Port-4) Pin 13: Orange (Ethernet Port-4) Pin 14: Orange (Ethernet Port-4) Pin 15: Orange (Ethernet Port-4) Pin 16: Orange (Ethernet Port-4) Pin 17: Orange (Ethernet Port-4) Pin 18: Orange (Ethernet Port-4) Pin 19: Orange (Ethernet Port-4) Pin 20: Orange (Ethernet Port-4) Pin 21: Orange (Ethernet Port-4) Pin 22: Orange (Ethernet Port-4) Pin 23: Orange (Ethernet Port-4) Pin 24: Orange (Ethernet Port-4) Pin 25: Pink (Ethernet Port-5) Pin 26: Pink (Ethernet Port-5) Pin 27: Pink (Ethernet Port-5) Pin 28: Pink (Ethernet Port-5) Pin 29: Pink (Ethernet Port-5) Pin 30: Pink (Ethernet Port-5) Pin 31: Pink (Ethernet Port-5) Pin 32: Pink (Ethernet Port-5) Pin 33: Pink (Ethernet Port-5) Pin 34: Pink (Ethernet Port-5) Pin 35: Pink (Ethernet Port-5) Pin 36: Green (CAN Port 1) Pin 37: Green (CAN Port 1) Pin 38: Green (CAN Port 1) Pin 39: Green (CAN Port 1) Pin 40: Green (CAN Port 1) Pin 41: Green (CAN Port 1) Pin 42: Green (CAN Port 1) Pin 43: Green (CAN Port 1) Pin 44: Green (CAN Port 1) Pin 45: Green (CAN Port 1) Pin 46: Grey (Serial 1-2) Pin 47: Grey (Serial 1-2) Pin 48: Grey (Serial 1-2) Pin 49: Grey (Serial 1-2) Pin 50: Grey (Serial 1-2) Pin 51: Grey (Serial 1-2) Pin 52: Grey (Serial 1-2) Pin 53: Grey (Serial 1-2) Pin 54: Grey (Serial 1-2) Pin 55: Grey (Serial 1-2) 													





















Wiring Table

Number of wires in cable: 55

Contacts used: 37

Contacts unused: 18

Note: Twisted pairs are indicated by ovals. Twisting is present in any supplied stock cables. If vendor supplies cables, the twisting must be observed.

D38999/26WE35PN Pin no.	Signal	External Connector Type	Internal connector Pin no.	Wire colour
1 	BI_DA+ P3	RJ45 jack	1	White-Orange
2 	BI_DA- P3		2	Orange
3 	BI_DB+ P3		3	White-Green
8 	BI_DB- P3		6	Green
4 	BI_DC+ P3		4	Blue
5 	BI_DC- P3		5	White-Blue
6 	BI_DD+ P3		7	White-Brown
7 	BI_DD- P3		8	Brown
10 	BI_DA+ P4	RJ45 jack	1	White-Orange
11 	BI_DA- P4		2	Orange
12 	BI_DB+ P4		3	White-Green
13 	BI_DB- P4		6	Green
17 	BI_DC+ P4		4	Blue
18 	BI_DC- P4		5	White-Blue
19 	BI_DD+ P4		7	White-Brown
20 	BI_DD- P4		8	Brown
25 	BI_DA+ P5	RJ45 jack	1	White-Orange
32 	BI_DA- P5		2	Orange
26 	BI_DB+ P5		3	White-Green
33 	BI_DB- P5		6	Green
27 	BI_DC+ P5		4	Blue
34	BI_DC- P5		5	White-Blue
28	BI_DD+ P5		7	White-Brown
35	BI_DD- P5		8	Brown
47	RS422_GND2	DB9-2 Male	5	White
48	RS422_RX2-		8	Grey
49	RS422_RX2+		2	Blue
50	RS422_TX2-		7	Purple
51	RS422_TX2+		3	Green

40	RS422_GND1	DB9-1 Male	5	Yellow
41	RS422_RX1-		8	Orange
42	RS422_RX1+		2	Brown
43	RS422_TX1-		7	Red
44	RS422_TX1+		3	Black
55	CAN 1_GND	DB9-3 Male	3	Red
54	CAN 1_L		2	Brown
53	CAN 1_H		7	Blue

10.5 J6: Ethernet, CAN, Serial

SabreCom-300 provides 3x Ethernet, 1x CAN, 2x Serial ports and these signals terminated on a E-sized D38999 series circular connector. All the above mentioned interfaces share the same connector.

Function: Ethernet port 6-8, CAN port-2, Serial port 3-4

Enclosure location: J6 (Lower Right)

Cable description

Internal connector	Connector type	MIL D38999/20WE35SA											
	Description	<table border="0"> <tr> <td>Shell type</td> <td>Straight Plug</td> </tr> <tr> <td>Material and finish</td> <td>Olive Drab Cadmium Plated Nickel Base</td> </tr> <tr> <td>Shell Size</td> <td>E</td> </tr> <tr> <td>Insert</td> <td>E35</td> </tr> <tr> <td>Arrangement</td> <td></td> </tr> </table>	Shell type	Straight Plug	Material and finish	Olive Drab Cadmium Plated Nickel Base	Shell Size	E	Insert	E35	Arrangement		
Shell type	Straight Plug												
Material and finish	Olive Drab Cadmium Plated Nickel Base												
Shell Size	E												
Insert	E35												
Arrangement													
Mating connector	Connector type	MIL D38999/26WE35PA											
	Description	<table border="0"> <tr> <td>Shell type</td> <td>Straight Plug</td> </tr> <tr> <td>Material and finish</td> <td>Olive Drab Cadmium Plated Nickel Base</td> </tr> <tr> <td>Shell Size</td> <td>E</td> </tr> <tr> <td>Insert Arrangement</td> <td>E35</td> </tr> <tr> <td>Contact type</td> <td>Pin</td> </tr> <tr> <td>Keying position</td> <td>Keying-A</td> </tr> </table>	Shell type	Straight Plug	Material and finish	Olive Drab Cadmium Plated Nickel Base	Shell Size	E	Insert Arrangement	E35	Contact type	Pin	Keying position
Shell type	Straight Plug												
Material and finish	Olive Drab Cadmium Plated Nickel Base												
Shell Size	E												
Insert Arrangement	E35												
Contact type	Pin												
Keying position	Keying-A												
Illustration	<ul style="list-style-type: none"> View from exterior of case View from terminal insertion side of mating connector 	<p>The diagram shows a circular connector with 55 pins arranged in a circular pattern. The pins are numbered 1 through 55. A legend on the right identifies the functions of the pins:</p> <ul style="list-style-type: none"> Blue: Ethernet Port 6 Orange: Ethernet Port 7 Pink: Ethernet Port 8 Green: CAN Port-2 Grey: Serial Port 3-4 											

























Wiring Table

Number of wires in cable: 55

Contacts used: 37

Contacts unused: 18

Note: Twisted pairs are indicated by ovals. Twisting is present in any supplied stock cables. If vendor supplies cables, the twisting must be observed.

D38999/26WE35PA Pin no.	Signal	External Connector Type	External connector Pin no.	Wire colour
1 	BI DA+ P6	RJ45 jack Ethernet Port 6	1	White-Orange
2 	BI DA- P6		2	Orange
3 	BI DB+ P6		3	White-Green
8 	BI DB- P6		6	Green
4 	BI DC+ P6		4	Blue
5 	BI DC- P6		5	White-Blue
6 	BI DD+ P6		7	White-Brown
7 	BI DD- P6		8	Brown
10 	BI DA+ P7	RJ45 jack Ethernet Port 7	1	White-Orange
11 	BI DA- P7		2	Orange
12 	BI DB+ P7		3	White-Green
13 	BI DB- P7		6	Green
17 	BI DC+ P7		4	Blue
18 	BI DC- P7		5	White-Blue
19 	BI DD+ P7		7	White-Brown
20 	BI DD- P7		8	Brown
25 	BI DA+ P8	RJ45 jack Ethernet Port 8	1	White-Orange
32 	BI DA- P8		2	Orange
26 	BI DB+ P8		3	White-Green
33 	BI DB- P8		6	Green
27 	BI DC+ P8		4	Blue
34 	BI DC- P8		5	White-Blue
28 	BI DD+ P8		7	White-Brown
35 	BI DD- P8		8	Brown
47	RS422_GND4	DB9-2 Male	5	White
48	RS422_RX4-		8	Grey
49	RS422_RX4+		2	Blue
50	RS422_TX4-		7	Purple
51	RS422_TX4+		3	Green
40	RS422_GND3		5	Yellow

41	RS422_RX3-	DB9-1 Male	8	Orange
42	RS422_RX3+		2	Brown
43	RS422_TX3-		7	Red
44	RS422_TX3+		3	Black
55	CAN 2_GND	DB9-3 Male	3	Red
54	CAN 2_L		2	Brown
53	CAN 2_H		7	Blue

11. EXTERNAL CABLE INTERFACE SUMMARY

SI No	Description	Connector PN	Pin Count	Keying	Quantity
1	Power Input	D38999/26WC4SN	4	N	1
2	USB3.0(Optional)	SJTG06RT12-35DP014	22	N	1
3	Ethernet Port-1	D38999/26WD35PN	37	N	1
4	Ethernet Port-2				
5	USB2.0 Port-1				
6	USB2.0 Port-2				
7	Serial Debug port				
8	HDMI	SJTG06RT12-35DP014	22	N	1
9	Ethernet Port-3	D38999/26WE35SN	55	N	1
10	Ethernet Port-4				
11	Ethernet Port-5				
12	CAN Port-1				
13	Serial Port-1				
14	Serial Port-2	D38999/26WE35SA	55	A	1
15	Ethernet Port-6				
16	Ethernet Port-7				
17	Ethernet Port-8				
18	CAN Port-2				
19	Serial Port-3				
20	Serial Port-4				

12. VENUS JUMPER CONFIGURATIONS

12.1 Jumpers on Venus Carrier Board

The Jumper blocks on the Venus COM carrier board can be configured to enable/disable or alter the default signal routing settings on the circuit, using Jumper shunts.

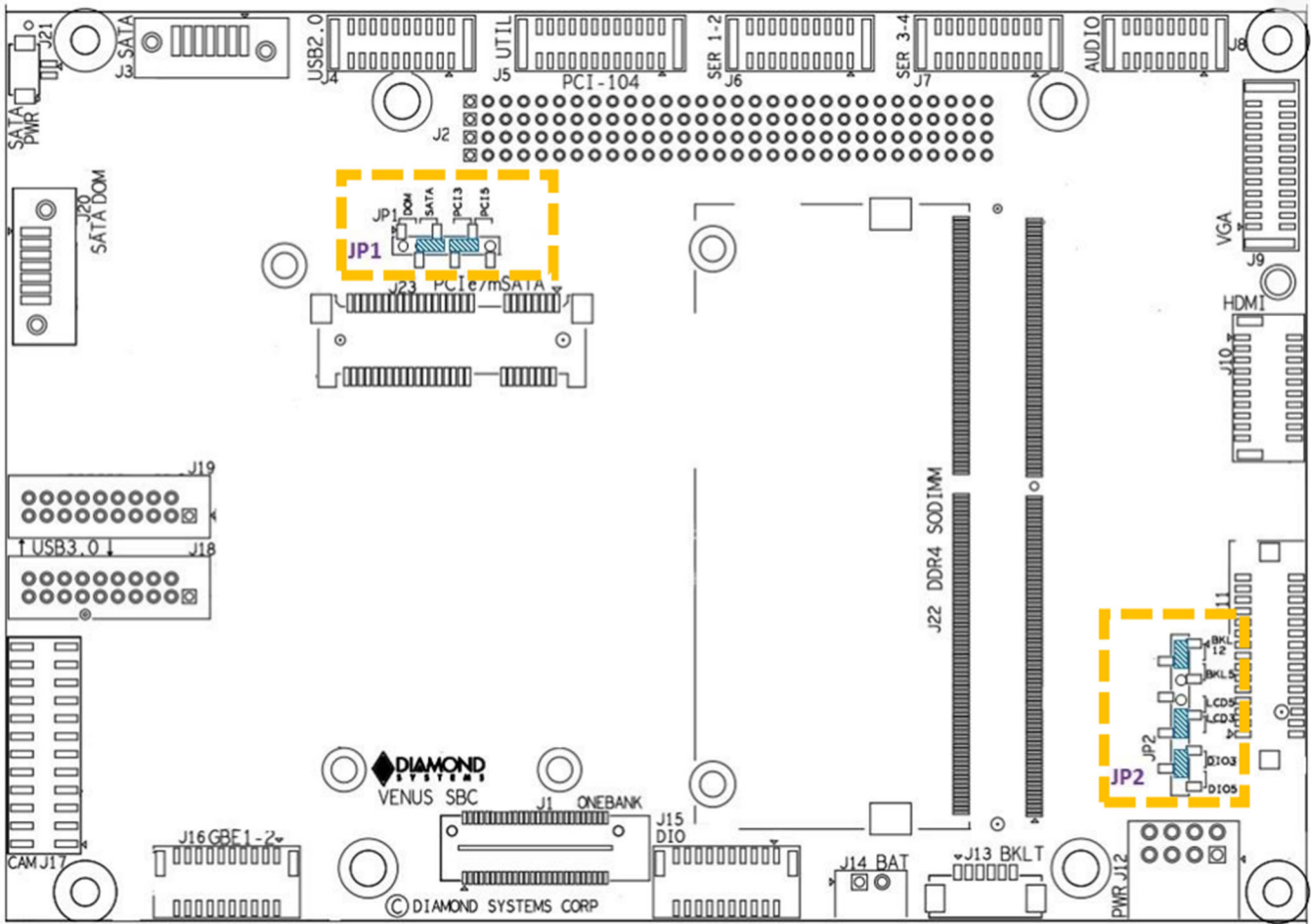

Figure 3: Jumper Blocks on Venus Carrier Board

Jumper Block Functions

Name	Function
JP1	SATA DOM Power, PCI VIO
JP2	LVDS LCD VCC and Backlight

13. BIOS KEY FEATURES

The Venus BIOS provides the following user configurable and controllable features:

- ◆ Boot from LAN (PXE) as well as USB and SATA ports
- ◆ Free boot sequence configuration to allow different boot sequences as first, second and third boot devices
- ◆ Support multi display mode. HDMI, VGA and LVDS can be active simultaneously
- ◆ Console (display and keyboard) redirection to a COM port
- ◆ Custom default settings can be saved without a battery
- ◆ Customizable splash screen
- ◆ Quiet boot option
- ◆ Enable/disable for individual COM ports.
- ◆ Protocol selection for each of the COM ports
- ◆ 120 ohm line termination control for serial ports in RS-422/485 protocol
- ◆ IRQ sharing for COM ports
- ◆ Enable/ disable Digital I/O ports A and B
- ◆ Direction control (Input/ Output) for Digital I/O ports A and B
- ◆ Wake on LAN for on-board Ethernet and minicard socket
- ◆ BIOS LED to indicate successful BIOS initialization
- ◆ Supports standard BIOS hotkey. This includes DEL key to enter BIOS menu; F3 key to load BIOS default settings etc.
- ◆ Password protection
- ◆ Field upgradable via a DOS/Shell utility

To achieve the maximum constant CPU speed which is 2.81 GHz, use the following BIOS settings:

Advanced -> CPU Configuration -> Intel (R) Speed Shift Technology - Disabled

Advanced -> CPU Configuration -> Intel (R) SpeedStep (tm) - Disabled

Advanced -> CPU Configuration -> Configurable TDP Boot Mode - Up

It is not possible to enable the Turbo Mode if one wishes to maintain the CPU speed constant. Because the Turbo Mode is under Intel (R) SpeedStep (tm) which should be disabled to achieve the maximum constant CPU speed.

The BIOS on Venus provides access to many valuable features. These instructions show how to enter the BIOS and set up features.

13.1 Entering the BIOS

The BIOS may be entered during startup by pressing the DEL key on an attached keyboard. Press the key repeatedly soon after a power-on or reset until the BIOS screen appears. After a specific period during startup (generally a few seconds), the BIOS will ignore the DEL key. If the system does not respond expectedly after pressing the DEL key, user can simply reset the board (or power down) and try again.

13.2 Restoring Default BIOS Settings

While making changes to the BIOS settings, the new settings are stored in SPI flash internal in the DX3 processor. If the user wants to restore the BIOS settings to default state, follow the procedure listed below.

1. Connect a keyboard to the USB keyboard port or PS/2 keyboard port and connect a monitor.
2. Reboot the CPU (reset or power-down and power-up).
3. Hold down the F3 key while the CPU is booting.
4. The board will boot up normally. The BIOS settings will be reset to their defaults.

End key functionality also works in BIOS menu. When the BIOS menu is displayed press the end key.

13.3 Upgrading BIOS using SHELL Utility

Please follow the below steps for BIOS programming through the SHELL Utility.

1. Copy the provided shell.efi and shellx64.efi, afuefix64.efi, FWUpdLcl.efi to USB flash disk root file. Make sure that this is not inside any folder.
2. Make sure that USB keyboard, Mouse and one of the display is connected.
3. Connect the USB flash disk to Venus board, power on the board, and boot to BIOS by pressing the DEL key.
4. In BOOT menu, enter launch shell based file systems to boot to shell as shown below.

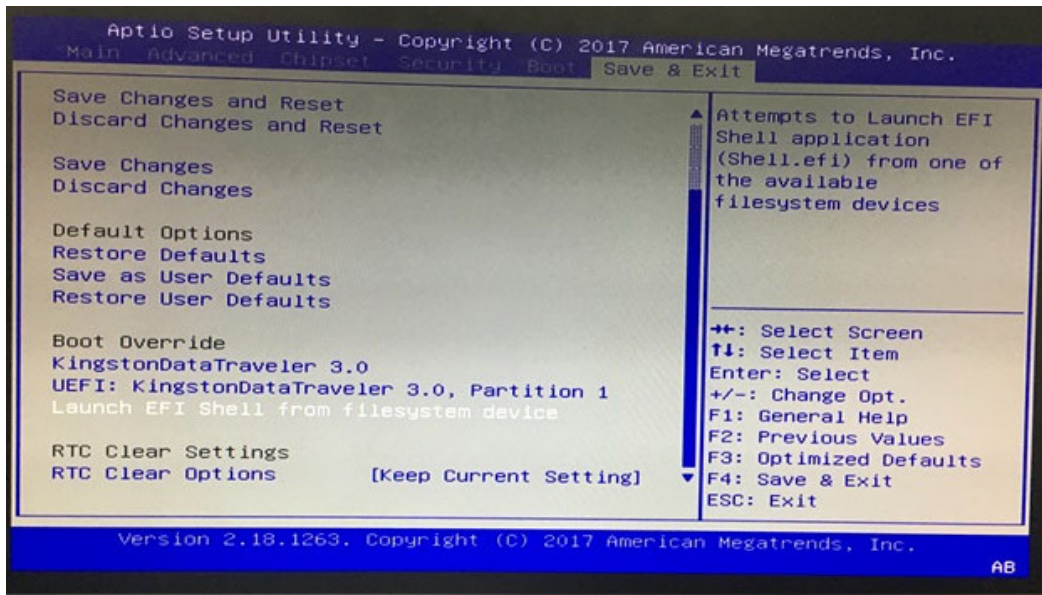

5. Once booted to shell, identify which is the file system for USB flash disk. It can be fs0 or fs1 or fs2. You can check this by pressing page up button.
6. Assuming it is fs0:, follow the below commands.

fs0:

afuefix64.efi <BIOS_filename>.bin /b /p /n

```
EFI Shell version 2.40 [5.103079215115]
Current running mode 1.1.2
Device mapping table
  fs0      :Removable HardDisk - Alias hd800b blk0
            PciRoot(0x0)/Pci(0x14,0x0)/USB(0xE,0x0)/HD(1,MBR,0x1B44DD62,0x800,0x1C
D125A)
  blk0     :Removable HardDisk - Alias hd800b fs0
            PciRoot(0x0)/Pci(0x14,0x0)/USB(0xE,0x0)/HD(1,MBR,0x1B44DD62,0x800,0x1C
D125A)
  blk1     :Removable BlockDevice - Alias (null)
            PciRoot(0x0)/Pci(0x14,0x0)/USB(0xE,0x0)

Press ESC in 1 seconds to skip startup.nsh, any other key to continue.
Shell> fs0:
fs0:\> afuefix64.efi Venus02_19_bios.bin /b /p /n_
```

7. After this BIOS will be programmed and status is displayed. Wait for 100% completion.

```
blk1 :Removable Block Device - Alias (null)
      PciRoot (0x0)/Pci (0x14,0x0)/USB (0xE,0x0)

Press ESC in 1 seconds to skip startup.nsh, any other key to continue.
Shell> fs0:

fs0:\> afuefix64.efi Venus02_19_bios.bin /b /p /n
-----+-----
|                               AMI Firmware Update Utility v5.08.00   |
|                               Copyright (C)2015 American Megatrends Inc. All Rights Reserved. |
|                               +-----+-----+                       |
+-----+-----+-----+-----+-----+-----+-----+-----+-----+
Reading flash ..... done
- ME Data Size checking . ok
- FFS checksums ..... OK
Erasing Boot Block ..... done
Updating Boot Block ..... done
Verifying Boot Block ..... done
Erasing Main Block ..... done
Updating Main Block ..... done
Verifying Main Block ..... done
Erasing NVRAM Block ..... done
Updating NVRAM Block ..... done
Verifying NVRAM Block ..... done

fs0:\> _
```

8. If in case Soft strap update is required follow the below command. Note that is this only for special case. Otherwise ignore this step.

FWUpdcl.efi -allowsv -f <ME_filename>.bin

9. Turn-off the board and power on again to confirm the programming by checking BIOS version in BIOS menu.

13.4 Setting the Date and Time

To set the date and time in the BIOS, select Main menu, then enter the date and time at the top of the screen. This screen also displays the CPU speed and memory capacity of the board.

13.5 Boot Priority

To select Boot devices and priority, go to the **Boot** menu and select **Boot Device Priority**. Only devices which are connected to the board will appear in the list of options. Therefore, if the user wants to select a hard drive or USB device as the boot device, CPU should be connected first, then boot up and enter the BIOS, then select it as a boot device. If this menu option does not appear on the screen, it means that the on-board flash drive is not enabled, and either no boot devices are attached or the CPU does not recognize any attached boot devices.

13.6 LED

A green BIOS LED has been provided to indicate that the board has been booted to BIOS GUI. The location of the BIOS LED is being shown in the Board Layout Section.

13.7 Quiet / Quick Boot / Splash Screen

Quiet boot replaces the system status and configuration screen that appears during startup with a blank screen or custom splash screen (if available). Quick boot turns off memory test during startup to save time. To enable these features, go to the Boot menu, then select Boot Settings Configuration. Diamond can provide custom splash screens upon request from an image file.

13.8 Serial Port Configuration

Venus provides 4 serial ports. All 4 ports support RS-232/422/485 functionalities. The functionality can be configured from the BIOS GUI. In BIOS setup go to advanced menu then Serial/Parallel port configuration. Select the appropriate mode for the Serial Ports.

14. GETTING STARTED

This section describes the steps needed to get Venus SBC up and running, and assumes that user also has a Venus Development Kit or Venus Cable Kit. The Cable Kit includes all cables needed for the I/O, except the LCD and backlight. The Development Kit includes the Cable Kit, an AC adapter to power the board, a SATA hard drive, and the hard drive programmer board.

14.1 Quick Setup

1. Attach HDMI cable.
2. Attach display, keyboard, and mouse (if needed) to the cables.
3. Connect the jumpers as mentioned in Section 8 for a default settings or can be changed as desired by the user.
4. Connect power (12V) to power input connector J1 using external power supply with power cable. The input connector and cable keyed to prevent incorrect connection. **WARNING: Attaching the power connector incorrectly will destroy the Venus SBC!**
5. For a quick verification that the system is set up and working properly, if no boot device is attached, the system will boot to BIOS mode.

14.2 Boot Device Options

Venus can boot from SATA or any of the available USB ports or PXE (10/100 Ethernet Port only). Either a board powered SATA DOM or an externally powered SATA HDD can be connected to the SATA port. DSC will provide a flash-disk (SATA DOM or mSATA) with pre-loaded OS.

WARNING: It is possible to destroy the Venus SBC by connecting a SATA cable incorrectly (reverse orientation or offset from correct position). Always use keyed cables to avoid connection errors.

The Boot device selection and priority are configured in the BIOS Boot menu. Only devices which are connected to the SBC will appear in the list of options. Therefore if user wants to select a hard drive or USB device as the boot device, the SBC should be connected first, then boot up and enter the BIOS, then select it as a boot device.

The following are a few example boot scenarios.

- ◆ Install an externally powered SATA hard drive directly on the SATA connector (J3).
- ◆ Attach a SATA DOM on the SATA connector (J20) (the Venus SBC will provide power to the SATA DOM over Jumper JP1 1-2)
- ◆ Attach a mSATA device on the Mini PCIe socket (J23)
- ◆ Attach a bootable USB device to one of the USB ports (J4,J18,J19).
- ◆ PXE boot over Ethernet (J16)

14.3 Installing OS and Booting

Ensure that SATA data cable and power cable are connected to SATA HDD.

Follow below steps to install Windows 8.1/10 operating system in SATA HDD.

- ◆ Connect a USB pen drive to a USB port of (J4) Venus board having Windows 10 installation image.
- ◆ Boot the Venus board to BIOS. The SATA HDD and USB device should be detected in BIOS under boot devices.
- ◆ Under boot priorities, set highest priority for USB.
- ◆ Save BIOS settings and restart.
- ◆ Windows 10 installer would start running. Follow the instructions in the installer.
- ◆ Upon successful installation, boot to Windows 10 and install the necessary drivers.
- ◆ For installing Windows 7 OS, special instructions need to be followed. Please contact DSC for the same.

15. VIDEO FEATURES

Venus SBC offers three video output options: 2 DDI and one eDP.(Default configuration is HDMI)

The DDI ports are configurable for either HDMI 1.4, DP 1.1a, or eDP. All the three outputs can be active at any time.

DDI port 1 is configured as HDMI 1.4 and supports a maximum resolution of 1920 x 1080 x 60Hz x 24bpp.

DDI port 2 is used for VGA and VGA is realized using DP to VGA converter. Maximum resolution of VGA is 1920 x 1200 x 60Hz x 24bpp.

An eDP to LVDS converter provides a dual-channel LVDS LCD output. Maximum LVDS resolution is 1920 x 1080 x 60Hz x 24bpp. The LCD backlight control is provided by a PWM circuit. LCD backlight power and control are on a separate latching connector.

BIOS will support option for selecting Single channel /Dual Channel, Color Depth, resolution and brightness control.

By default, BIOS will support 7 EDID configuration Emulation as shown in below table. Correct resolution need to be selected based on the LCD used. Please contact DSC for the EDID values OR one can use PTN3460 DPCD utility for changing the configuration.

EDID NO	Resolution	EDID Description
0	1024 x 768 @60Hz	NXP Generic
1	1920 x 1080 @60Hz	NXP Generic
2	1920 x 1080 @60Hz	NXP Generic
3	1600 x 900 @60Hz	Samsung LTM200K
4	1920 x 1080 @60Hz	Samsung LTM200K
5	1366 x 768 @60Hz	NXP Generic
6	1600 x 900 @60Hz	ChiMei M215HGE

16. SERIAL PORTS AND SYSTEM CONSOLE

16.1 Configuration

The Venus SBC supports total 4 serial ports. All the 4 ports support RS-232/422/485 modes. The modes can be configured in BIOS. Both TX and RX termination selection option are available under BIOS menu.

16.2 Console redirection

Connect any of the serial ports to a PC and run a terminal emulator program such as Hyperterminal. In BIOS menu, go to Advanced settings menu, then in Remote Access Configuration enable the Remote access feature. Then select the serial port. User should see the BIOS setup menu in the PC console.